

133393A, 133392A, 137253A Replacement Seals for V5055, V5097 Gas Valves

INSTALLATION INSTRUCTIONS

APPLICATION

Use these seals to replace the old ones when removing the V5055/V5097 bonnet for cleaning or inspection. There are three seal packages for the V5055/V5097:

- 133393A: 3/4, 1-1/4 and 1-1/2 inch valves.
- 133392A: 2, 2-1/2, and 3 inch valves.
- 137253A: 4-inch valves.

Each package includes a bonnet seal, a valve seal (see Fig. 1), and a tube of grease.

The stem seal is not replaceable. If replacement is desired, order the appropriate bonnet assembly.

NOTE: The bonnet assembly includes seals.

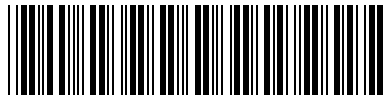

INSTALLATION

WARNING

Explosion Hazard.

Can cause serious injury, death or property damage.

1. Only a trained, experienced service technician should service the V5055/V5097 Gas Valve.
2. Before beginning installation, turn off the gas supply and disconnect the power supply to the valve actuator.
3. After installation, perform a complete checkout including a gas leak check.

The bonnet and valve seals may be replaced without removing the valve body from the gas line.

Use the following procedure to replace the seals in the V5055/V5097 Gas Valve:

1. Turn off the gas supply at the upstream manual shutoff valve.
2. Shut off all electrical power to the valve actuator.
3. If a 7616BR Crank Arm Assembly is used with the actuator, remove the crankarm assembly by pulling the clip and loosening the clamp screw. Disengage the arm from the actuator.
4. Remove the actuator from the valve (loosen the two set screws).
5. Remove the valve bonnet (four bolts on the 3/4 to 1-1/2 in. valves, six bolts on the 2- to 3-in. valves, and eight bolts on the 4-in. valves). Discard the old rubber seals.
6. Coat the new rubber seals with the grease provided and position them as shown in Fig. 1 or 2.

WARNING

Explosion Hazard.

Can cause serious injury, death or property damage.

Failure to properly position and seat the seals in the valve body may result in a hazardous gas leak.

7. Carefully seat the bonnet assembly on the valve body. Be sure the seals are in the proper positions. On V5055/V5097 Gas Valves that have a spring below the disk, be sure the spring is centered in the indentation on the inside of the valve body.

NOTE: The 4-inch bonnet assembly may be replaced in any position on the valve body.

8. After positioning the bonnet assembly, replace the screws removed in step 5 (see Fig. 3).

NOTE: When replacing the bonnet assembly on the 4-inch valve, be sure to draw it evenly into the valve body. Finger tighten the eight screws. Draw the bonnet assembly into the valve by tightening, in order, screws 1,5,7, and 3 (two turns each). See Fig. 3. Repeat until the bonnet assembly is seated. Tighten the remaining screws.

9. Remount the actuator. Securely tighten the set screws (50 to 60 inch-pounds).
10. Replace the crank arm assembly if disconnected in step 3.
11. With the gas still off, cycle the actuator to check for proper mechanical operation.

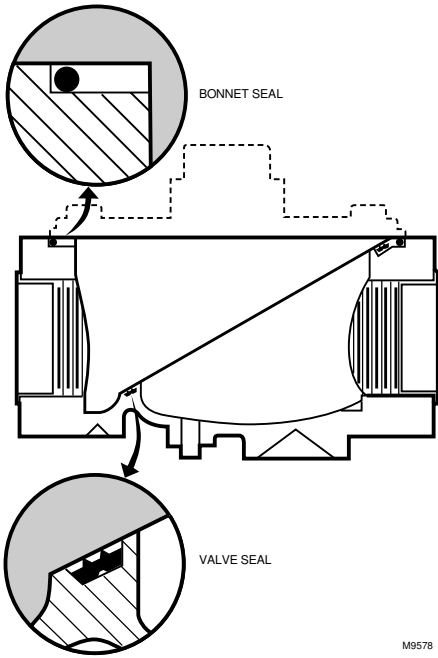

Fig. 1. Placement of valve and bonnet seals.

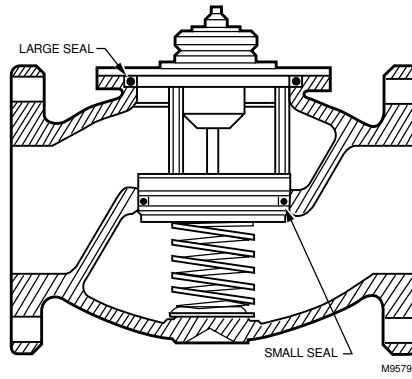

Fig. 2. Placement of valve and bonnet seals in four inch valve.

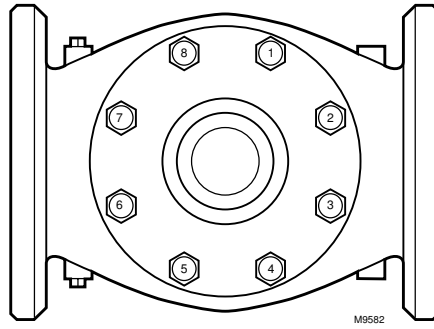

Fig. 3. Replacement V5055B/V5097B 4-inch valve bonnet assembly .

CHECKOUT

⚠️ WARNING

Explosion Hazard.

Can cause serious injury, death or property damage.

Both bonnet seal and seat leak checks must be performed after installation.

Bonnet Check

After the bonnet assembly is reinstalled, turn on the gas at the manual valve and check for gas leakage around the bonnet seal. Paint the seal area with a rich soap and water solution. Bubbles indicate a gas leak. If a leak is detected, check to see that the bonnet screws are tight. If necessary, turn off the gas again and remove the bonnet to be sure the seals are properly seated.

Seat Leak Check

Instructions for testing tightness closure of gas safety shutoff valves on burner startup (by qualified personnel). See Fig. 4.

1. De-energize control system to assure no power to the safety shutoff valve. (C)
2. Close upstream manual gas cock. (A)
3. Make sure manual test petcock (F) is closed in leak test tap assembly. (D)
4. Remove leak test tap plug and connect test apparatus to leak test tap (D) as shown in Fig. 4.
5. Close downstream manual gas cock. (E)
6. Open upstream manual gas cock. (A)
7. Program safety shutoff valve (C) to fully open position (through safety system); then immediately de-energize to seat valve operationally.
8. Immerse 1/4-inch tube vertically 1/2 inch into jar of water as shown in Fig. 4.
9. Slowly open test petcock. (D)
10. When rate of bubbles coming through water stabilizes, count the number of bubbles appearing during a 10 second period. Each bubble appearing during a 10-second period represents a flow rate of approximately 0.001 cf/h. If two safety shutoff valves are used, check each valve for closure tightness. To meet U.S. requirements, leakage must not exceed the values given below:

Table 1. Valve allowable leakage rate.

V5055/V5097 Pipe Size (in.)	Allowable Leakage (cc/hr) ^a	Number of Bubbles per ten seconds
3/4, 1, 1-1/4, 1-1/2	458	16
2, 2-1/2, 3	752	26
4	1003	35

^a Based on air at standard conditions, test pressures provided by ANSI Z21.21, Section 24.2 and a maximum of 235 cc/hr per inch of seal-off diameter. Seal-off diameter is not to be confused with pipe size.

11. Shut upstream manual gas cock. (A)
12. Close test petcock (F), remove test apparatus, and replace leak test tap plug. (D)
13. Open upstream manual gas cock. (A)
14. Open downstream manual gas cock. (E)
15. Restore system to normal operation and observe through one complete cycle to assure proper operation. If two safety shutoff valves are used, check each valve for closure and tightness.

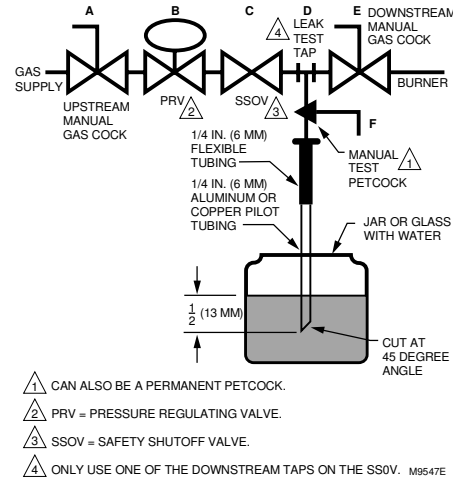

Fig. 4. Valve Leak Test.

Honeywell

Home and Building Control
 Honeywell
 1985 Douglas Drive North
 Golden Valley, MN 55422

Home and Building Control
 Honeywell Limited-Honeywell Limitée
 35 Dynamic Drive
 Scarborough, Ontario
 M1V 4Z9